

SPI Serial Peripheral Interface

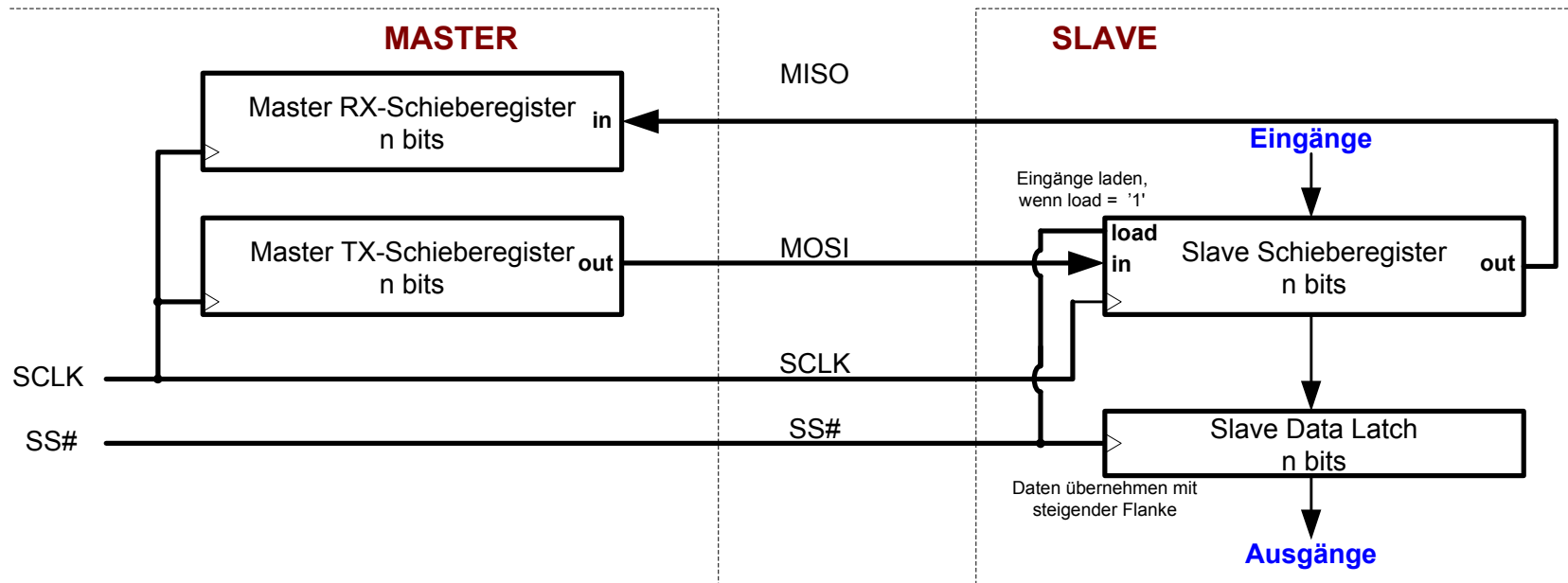

MISO = Master In, Slave Out
 MOSI = Master Out, Slave In

SCLK = Clock, erzeugt vom Master
 SS# = Slave Select, low-aktiv, erzeugt vom Master

